

KOSMO[®] Femoral Stem System

Restore Activity

This documentation is intended for health care professionals and the b-ONE ORTHO sales force.
Distribution to any other recipient is prohibited.

Information on the products and procedures contained in this document is of a general nature and does not represent and does not constitute medical advice or recommendations. The treating surgeon is responsible for determining the appropriate treatment, technique(s), and product(s) for each individual patient. b-ONE ORTHO does not dispense medical advice and recommends that surgeons be trained in the use of any particular product before using it in surgery.

Contact your b-ONE representative if you have questions about the availability of b-ONE products in your area.

All content herein is protected by copyright, trademarks and other intellectual property rights owned or licensed to b-ONE ORTHO Corp, or its affiliates unless otherwise indicated, and must not be redistributed, duplicated or disclosed, in whole or in part, without the express written consent of b-ONE ORTHO.

Please refer to the following for compatible surgical techniques:

b1LIT-00001 Tapered Wedge Femoral Stem System Surgical Technique
b1LIT-00047 Direct Anterior Approach Surgical Technique

BIOLOX[®] delta is a trademark of CeramTec AG.

b1LIT-00051 KOSMO Bone Compacting Femoral Stem Surgical Technique Rev. B
©2021 b-ONE ORTHO

 **b-ONE ORTHO Corp.**
3 Wing Drive, Suite 259
Cedar Knolls, NJ 07927
USA
www.b1.co

b-ONE
O R T H O

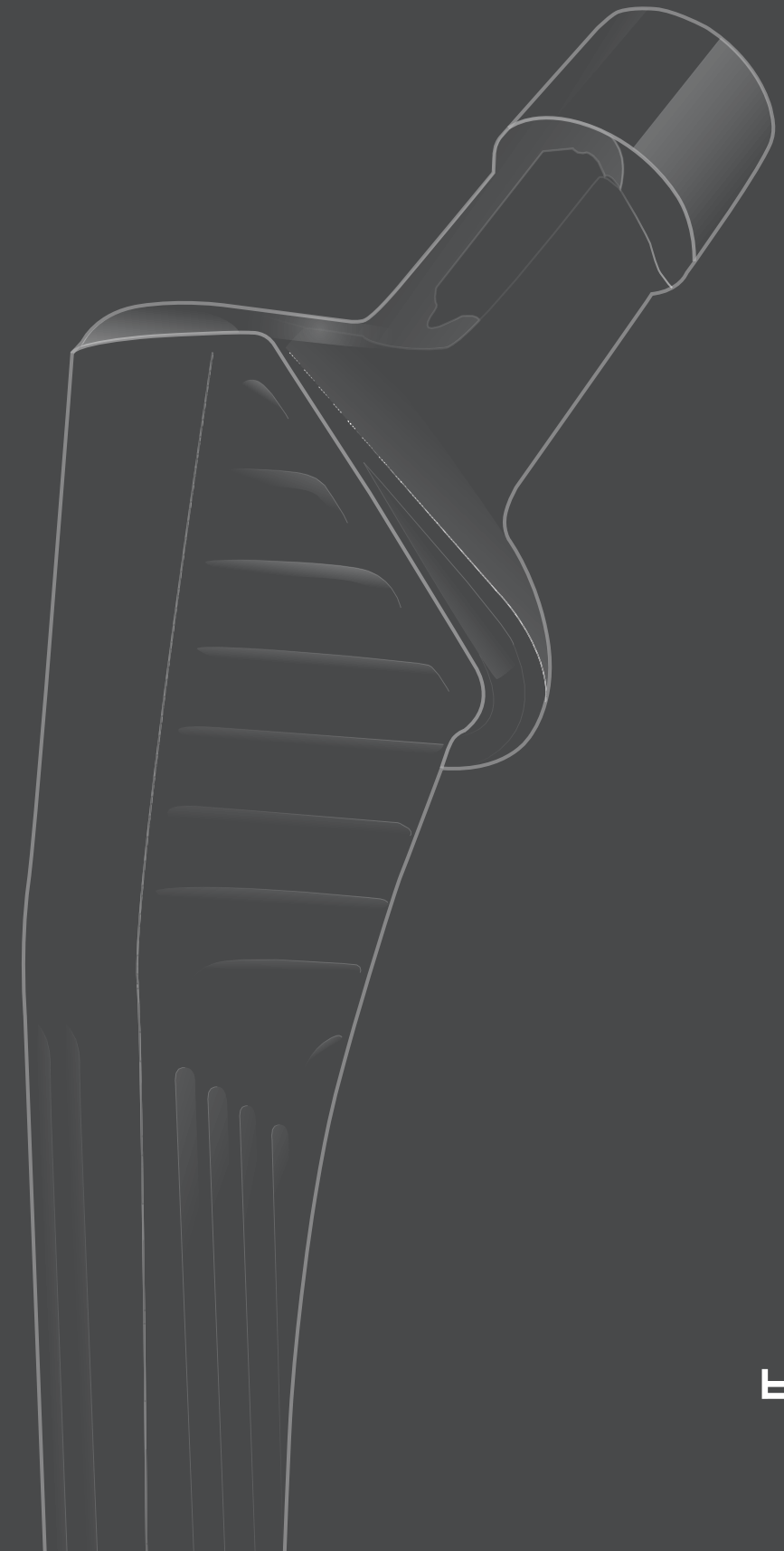

TABLE OF CONTENTS

01 | System Overview

02 | Indications and Contradictions

03 | Pre-Operative Templating

05 | Femoral Neck Resection

06 | Preparing the Femoral Canal

07 | Broaching

09 | Trial Reduction

10 | Head Trial

11 | Implanting the Stem

12 | Femoral Head

13 | Implanting the Femoral Head

14 | Implant Removal

15 | Implant Information

16 | Instrumentation

SYSTEM OVERVIEW

The KOSMO™ Femoral Hip System is a bone compacting femoral stem that is intended for Cementless and Cemented fixation. This hip stem is evolved from a traditional bone compacting design to optimize fit throughout a wide demographic of patient anatomies with a size-specific medial curvature geometry and fixed neck length design across the stem families.

The versatile stem design incorporates a reduced proximal lateral shoulder, a lateral distal relief, and an overall shorter stem length compared to traditional designs to allow ease of insertion in various surgical approaches.

The KOSMO™ Femoral Hip System is a broach-only system comprised of simple, intuitive instruments designed to optimize operative workflow and efficiency. Instrumentation carriers are designed to seamlessly stack into SterilContainers™ by Aesculap® or can be processed individually to accommodate hospital protocol or preference.

The KOSMO™ Hip System includes:

- Cementless HA coated stems offered in 6 families of collared and collarless design.
- Each of the collared and collarless options are offered in 3 different neck offsets,
 - ⦿ Standard and High Offset (135° neck angle)
 - ⦿ Coxa Vara (125° neck angle)
- Cemented stem offered in collarless design.
 - ⦿ Standard (135° neck angle)
- 13 femoral stem sizes ranging from size 1 to 10 with half sizes of 6.5, 7.5 and 8.5 for each family.

The KOSMO™ hip stem is designed for use with b-ONE® 12/14 femoral heads and their compatible acetabular components. b-ONE® Femoral Head implants are available as cobalt chrome (CoCr) or BIOLOX® *delta* (ceramic). KOSMO™ Cementless Femoral Stems can be used with either CoCr or Ceramic heads options, while the KOSMO™ Cemented Femoral Stem can be used with Ceramic heads only.

BIOLOX® is a registered trademark of CeramTec GmbH.

INDICATIONS AND CONTRADICTIONS

INDICATIONS

The b-ONE® Total Hip System is intended for primary or revision total hip replacement in skeletally mature patients with a severely disabled hip joint and/or hip damage due to the following conditions:

Osteoarthritis, traumatic arthritis, avascular necrosis of the femoral head, noninflammatory degenerative joint disease (NIDJD), slipped capital epiphysis, fused hip, fracture of the pelvis, and diastrophic variant. Hip components are also indicated for inflammatory degenerative joint disease including rheumatoid arthritis and congenital dysplasia; treatments of nonunion, acute traumatic fracture of the femoral head or neck; failed endoprosthesis, femoral osteotomy, or Girdlestone resection; and fracture-dislocation of the hip.

The b-ONE® Total Hip System KOSMO™ HA coated stems are intended for cementless use only.

The b-ONE® Total Hip System KOSMO™ stainless steel stems are intended for cemented use only.

b-ONE® Total Hip System components are not intended for use with other total hip systems.

CONTRAINDICATIONS

- Use of this system is contraindicated when there is active systemic infection, infection localized to the site of the proposed implantation, or when the patient has demonstrated allergy or foreign body sensitivity to any of the implants materials.
- Severe osteoporosis or osteopenia may prevent adequate fixation and thus preclude the use of these or any other orthopedic implants.
- Conditions that may place excessive stresses on bone and implants, such as severe obesity, or pregnancy, are relative contraindications. The decision to use these devices in such conditions must be made by the physician taking into account the risks versus the benefits to the patient.
- Use of these implants is relatively contraindicated in patients whose activity, mental capacity, mental illness, alcoholism, drug abuse, occupation, or lifestyle may interfere with their ability to follow postoperative restrictions and who may place undue stresses on the implant during body healing and may be at a higher risk of implant failure.
- Using a BIOLOX® *delta* head in combination with a prosthesis stem left in situ in a revision surgery is contraindicated. A BIOLOX® *delta* head must only be used with a brand-new, unused, and undamaged stem taper.

See package insert (b1INS-00004) for warnings, precautions, adverse effects, and other detailed product information.

PRE-OPERATIVE TEMPLATING

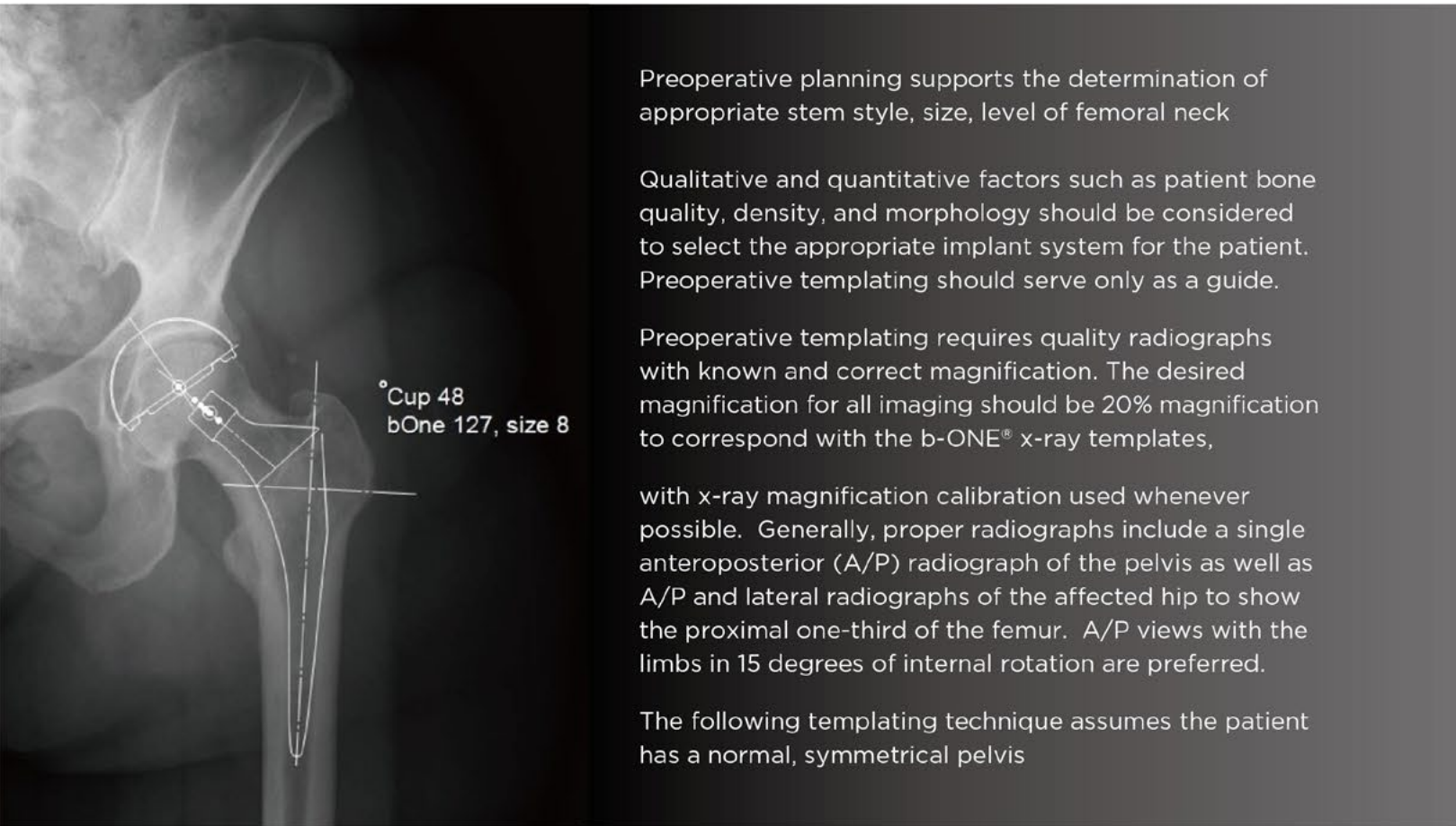

Preoperative planning supports the determination of appropriate stem style, size, level of femoral neck

Qualitative and quantitative factors such as patient bone quality, density, and morphology should be considered to select the appropriate implant system for the patient. Preoperative templating should serve only as a guide.

Preoperative templating requires quality radiographs with known and correct magnification. The desired magnification for all imaging should be 20% magnification to correspond with the b-ONE® x-ray templates,

with x-ray magnification calibration used whenever possible. Generally, proper radiographs include a single anteroposterior (A/P) radiograph of the pelvis as well as A/P and lateral radiographs of the affected hip to show the proximal one-third of the femur. A/P views with the limbs in 15 degrees of internal rotation are preferred.

The following templating technique assumes the patient has a normal, symmetrical pelvis

Template Acetabulum

Overlay the acetabular template on the x-ray, ensuring the medial border of the cup approximates the ilioischial line, and the inferior border of the cup is at the inferior aspect of the teardrop. The cup should be positioned with an abduction angle of 40-45 degrees. Mark the center of rotation of the acetabular component.

Check b1LIT-00002 for b-ONE Primary Acetabular Technique.



Assess Leg Length



First note any possible hip flexion contracture which could make the leg appear short on x-ray. Use clinical evaluation with radiographic analysis to determine intraoperative leg length management.

Beginning with the A/P of the pelvis, draw a reference along the inferior border of the ischial tuberosities, ensuring the line extends beyond the medial cortices of the femurs. Alternatively, a reference line through the inferior aspect of the teardrop landmarks

can be used. Then mark a reference point on each femur, such as the most proximal aspect of each lesser trochanter. Measure the distance between the reference line and each femoral reference point. Often, a line parallel to the reference line is drawn through each femoral reference point to assist with this measurement. The difference between the two measurements will indicate leg length discrepancy.

Template Femur

The KOSMO™ femoral stem has three offset options: the standard offset 135° neck angle, the high offset 135° neck angle and the Coxa Vara offset 125° neck angle. The KOSMO™ template has markings that indicate the center of the femoral head for the range of head options for each femoral neck offset option. Choose the appropriate stem size that achieves mediolateral cortical engagement at the proximal two-thirds of the stem and recreates the desired leg length and offset.

The relative positioning of the head center of rotation markings on the femoral template with respect to the acetabular center of rotation previously marked on the x-ray will predict the change in leg length and offset. For example, a given head center of rotation marking superior to the acetabular center of rotation mark will lengthen the limb, while a head center of rotation inferior to the acetabular center of rotation will shorten the limb. The desired change in leg length

is determined by the radiographic leg length inequality and clinical evaluation previously determined. The predicted change in offset is also considered by comparing the relative medial/lateral position of the center of rotation markings of the femoral and acetabular components.

Mark the anticipated neck resection level. This will be used as a reference during neck resection.



FEMORAL NECK RESECTION

The neck resection level affects the final fit and placement of the stem.

The Neck Resection Guide can aid in marking the appropriate neck resection level by placing it on the anterior/posterior aspect of the exposed femur, with the centerline aligned with the axis of the femoral canal. Care should be taken to reference the anatomic landmarks determined during preoperative templating, as well as visual inspection in relation to the lesser trochanter prior to making the cut. After the femoral resection is marked, the resection is made with an oscillating saw.

To remove the femoral head, a Modular Corkscrew is available and can be connected to the modular T-Handle or power. After the femoral head is removed, typically the acetabulum is prepared for the acetabular component (see b-ONE® Primary Acetabular Surgical Technique b1LIT-00002).



PREPARING THE FEMORAL CANAL

Access the Femoral Canal

Position the leg to provide the best exposure for preparation of the femoral canal. Use the Modular Box Osteotome, connected to the Modular Handle, and Mallet, to initiate entry into the femoral canal. Ensure the orientation of the Box Osteotome reflects the desired anteversion, which is typically 10-15 degrees.

Connect the Starter Reamer to the T-Handle or power and create a pathway into the medullary canal. To minimize the risk of varus placement or under-sizing of the femoral prosthesis, remove adequate bone from the lateral aspect of the canal with the Starter Reamer, Box Osteotome, or a rongeur.



TRIAL REDUCTION

Neck Trial

The KOSMO™ hip stem is designed with fixed neck length design across all stem sizes to provide an optimal patient fit. The neck trial options are:

- Standard Offset (135°)
- High Offset (135°)
- Coxa Vara (125°)

Choose the desired neck trial and assemble onto the broach.



- Standard offset**
- Length: 39mm
 - Neck angle: 135°



- High offset**
- Length: 43mm
 - Neck angle: 135°

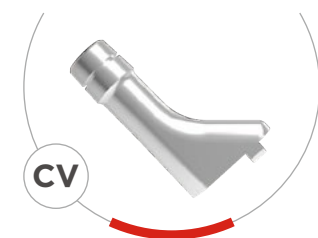

- Coxa Vara**
- Length: 40mm
 - Neck angle: 125°

The neck lengths are shown in images above. The neck trials are labeled according to corresponding offset of the stem.

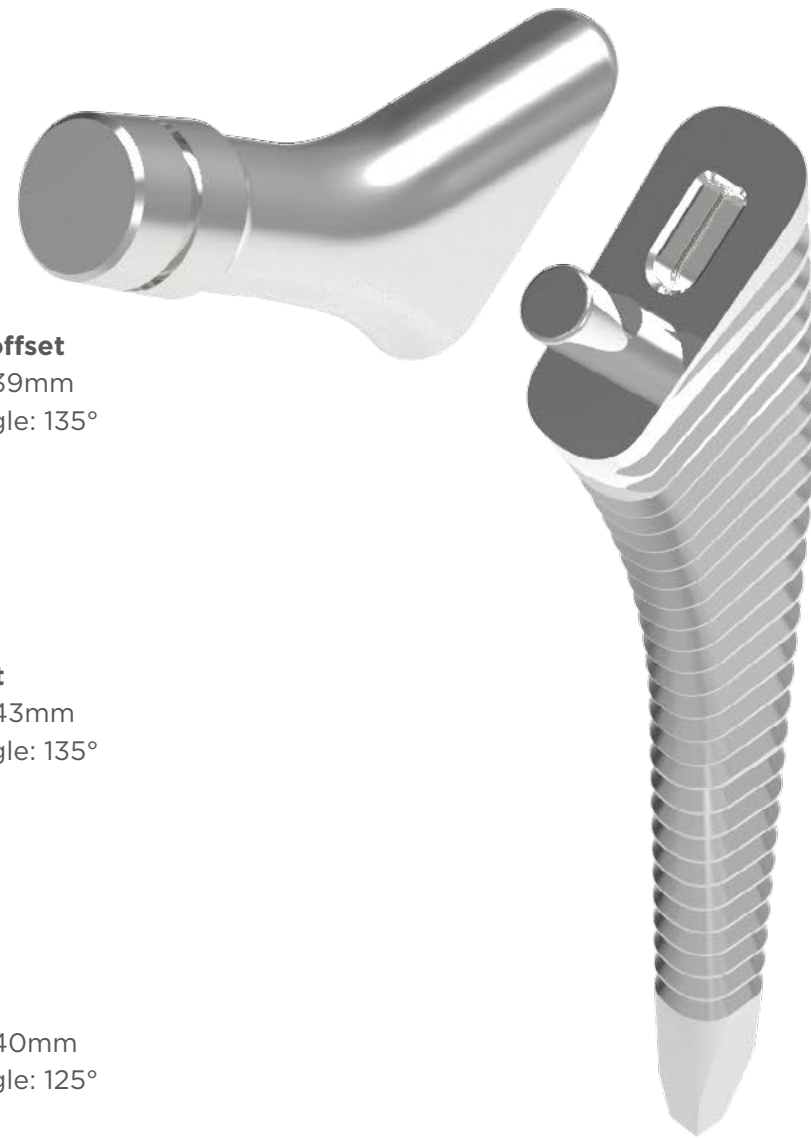

HEAD TRIAL

Insert the appropriate b-ONE® 12/14 taper head trial onto the neck trial. Note the femoral head offsets differ depending on the femoral head size as shown in the chart below:

HEAD DIAMETER	OFFSET			
	S	M	L	XL
22mm;22.2mm	0	2	4	N/A
28mm	-3.5	0	3.5	7
32mm	-4	0	4	7
36mm	-4	0	4	8

When performing the trial reduction, it is recommended to perform the following:

- Inspect the reduction of the femoral head in the acetabular cup. The reduction should be concentric and the appropriate amount of coverage of the femoral head achieved.
- Appropriate tissue tension should be assessed. Pulling the leg in a neutral position is important to obtain a true assessment of tissue tension.
- Assess stability through a full functional range of motion, checking any maneuvers that lead to instability. Note any acetabular osteophytes that may cause the hip to sublux out of the cup.
- Assess the leg lengths.

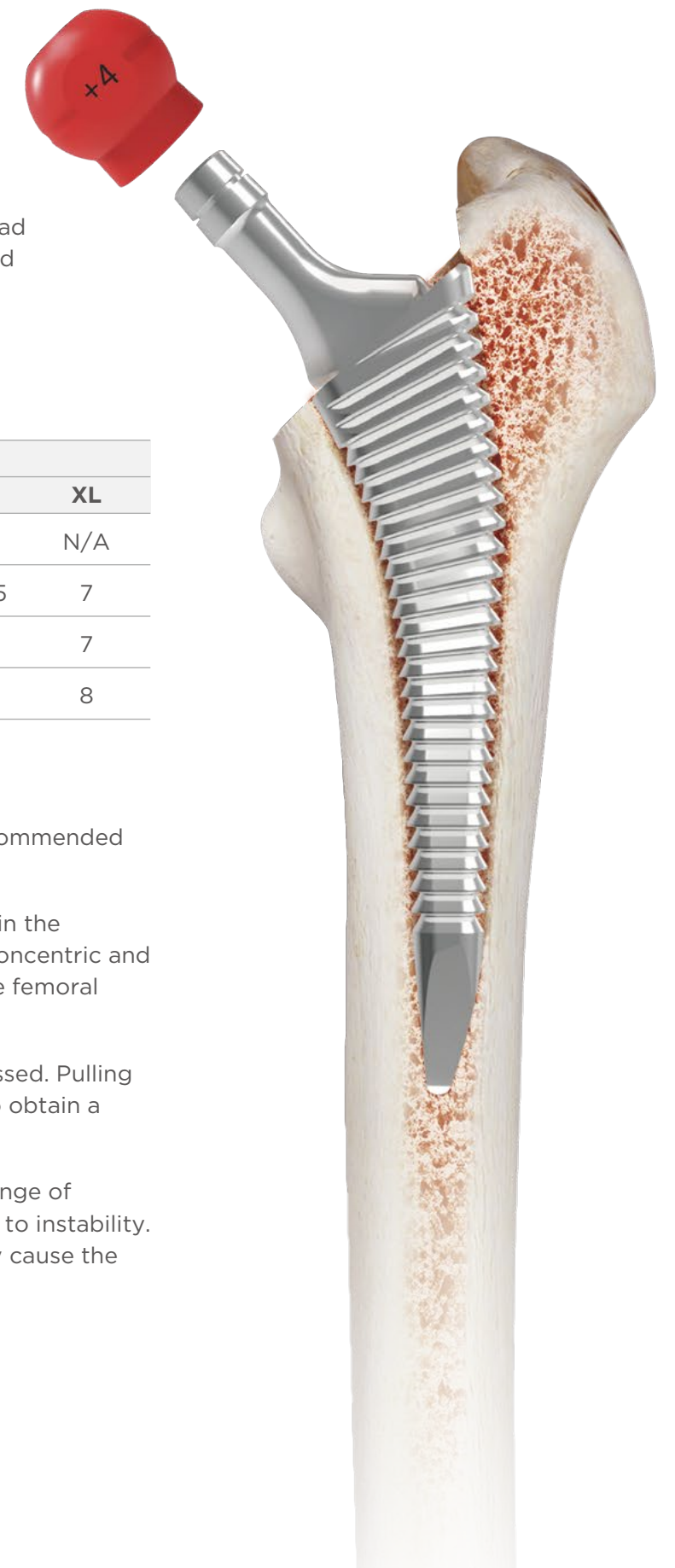

IMPLANTING THE STEM

Once the final construct is determined, remove all trial components from the body. Ensure that the selected stem size matches the broach and neck trial combination that was determined during the trial procedure.



Curved Inserter



Threaded Insertion

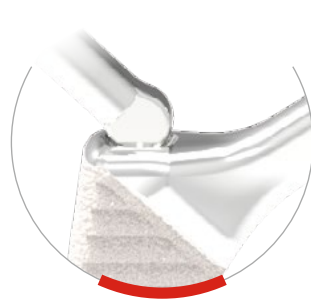

Scallop Impactor

The KOSMO™ Femoral Stem can be placed into the prepared canal by hand and seated with the femoral stem impactor.

To impact the stem, choose either the Scallop Impactor or Straight Stem Impactor and connect to the Modular Axial Handle.

Place the prosthesis in the femoral canal, ensuring the correct version prepared during femoral preparation. Position the assembled impactor/insertor into the impaction slot on the superior lateral aspect of the prosthesis. The Scallop Impactor allows for non-colinear impaction of the stem. Impact the assembled Femoral Impactor/insertor with the Mallet until the stem is fully seated.

NOTE: The Scallop Impactor or Straight Stem Impactor do not lock to the prosthesis. If a threaded insertion tool is preferred, the Stem Remover can be used. Attach the Stem Remover to the Modular Axial Handle and thread the Stem Remover into the threaded hole contained in the impaction slot of the prosthesis. Proceed with implantation as previously described.



FEMORAL HEAD

The KOSMO™ Cementless Femoral Stem is compatible with all b-ONE® 12/14 Taper Femoral Heads. b-ONE® Femoral Head implants are available as cobalt chrome (CoCr) or BIOLOX® *delta* (ceramic).

NOTE: The BIOLOX® *delta* ball head must only be used with a brand-new, unused, and undamaged stem taper. Prior to placement of the BIOLOX® *delta* head on the stem taper, the stem taper must be rinsed thoroughly and dried carefully. The stem taper and the inner taper of the BIOLOX® *delta* head must be inspected carefully, and any foreign bodies must be removed.



The image above shows the BIOLOX® *delta* head with the Primo™ Acetabular System

IMPLANTING THE FEMORAL HEAD

Remove the impactor/insertor. Perform the trial reduction steps with the trial head component on the femoral prosthesis to confirm the final femoral head implant neck length.

Once the final femoral head implant is selected and confirmed, remove the Femoral Head Trial and ensure the taper of the femoral prosthesis is clean and dry.

Assemble the Modular Head Impactor to the Modular Axial Handle. The final head implant is placed on the femoral taper. The BIOLOX® *delta* head must be fixed on the stem taper by using slight axial pressure and twisting at the same time.

Rest the plastic end of the assembled Head Impactor on the pole of the femoral head, ensuring the Head Impactor axis is aligned with the femoral stem neck axis, and with one or several moderate strikes of the Mallet, impact the Head Impactor to seat the femoral head.

Confirm the femoral head is secure on the femoral prosthesis by applying traction on the femoral head implant while confirming stability on the trunnion of the femoral stem.

Inspect the acetabulum for any bone or soft tissue interference and then reduce the hip. The hip biomechanics should be reassessed before closure.

Attention to detail during closure will improve stability and wound healing. Postoperative care is determined by surgical technique, patient factors, and surgeon preference and judgement.



Caution: The BIOLOX® *delta* head must never be struck with a mallet directly. Only the b-ONE® Modular Head Impactor should be used.

IMPLANT REMOVAL

If the stem must be removed, the impaction slot of the femoral prosthesis contains a threaded hole that mates with the Stem Remover. Clean the impaction slot and threaded hole thoroughly to ensure debris does not prevent engagement of the Stem Remover threads. Attach the Stem Remover to the Modular Axial Handle. Thread the assembled Stem Remover into the threaded hole of the prosthesis, being careful to avoid cross-threading.

Proceed to reverse impact the stem remover handle with a mallet to remove the stem.

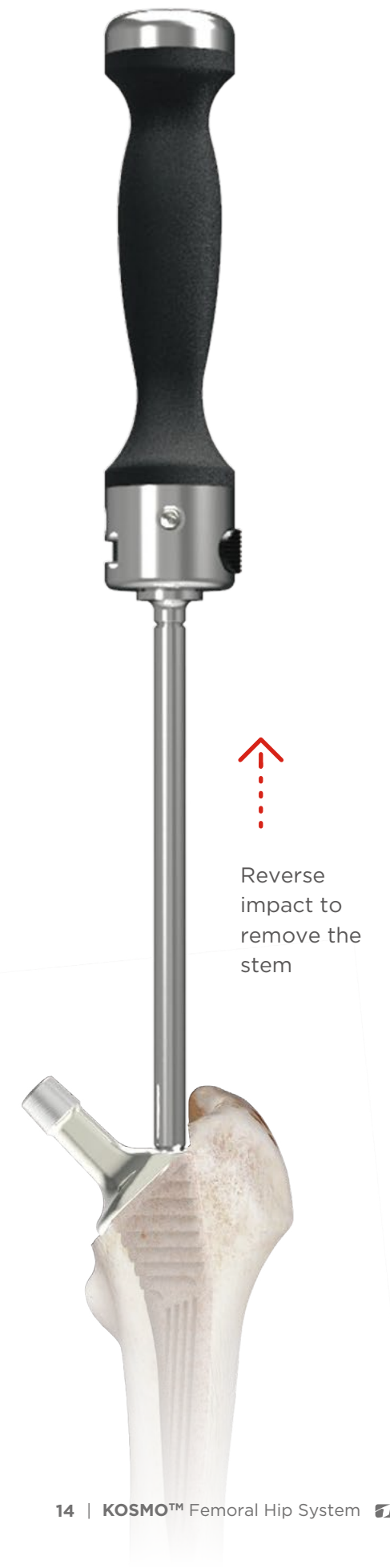

Reverse impact to remove the stem

IMPLANT INFORMATION

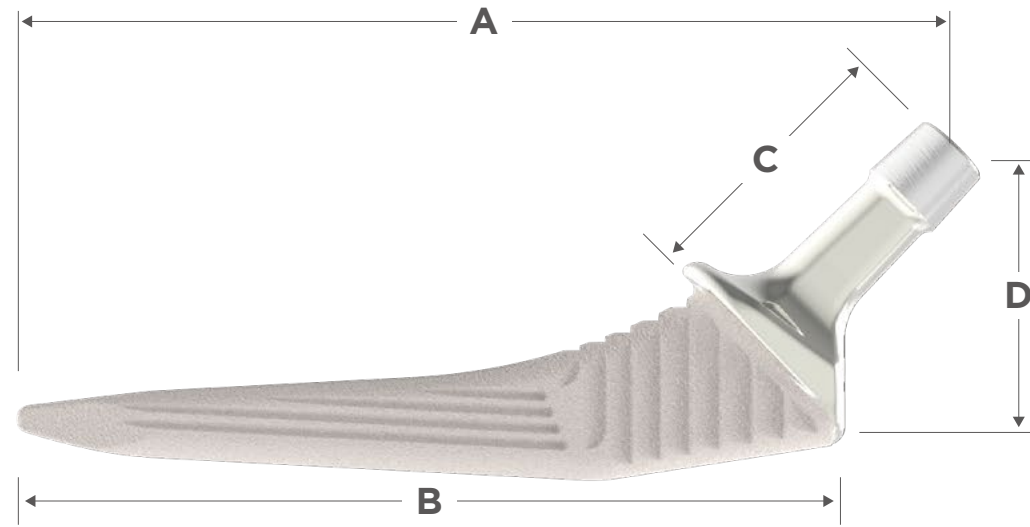

Size	Type	A	B	C	D
		Stem Length	Coating Length	Neck Length	Offset
1	Standard Offset 135°	134	120	39	39
2		139	125	39	40
3		144	130	39	40
4		149	135	39	41
5		159	145	39	42
6		164	150	39	42
7		169	155	39	43
8		174	160	39	44
9		184	170	39	45
1	High Offset 135°	129	120	43	46
2		134	125	43	46
3		139	130	43	46
4		144	135	43	47
5		154	145	43	48
6		159	150	43	49
7		164	155	43	50
8		169	160	43	51
9		179	170	43	52
1	Coxa Vera 125°	129	120	40	45
2		134	125	40	46
3		139	130	40	47
4		144	135	40	48
5		154	145	40	48
6		159	150	40	49
7		164	155	40	50
8		169	160	40	51
9		179	170	40	52

INSTRUMENTATION

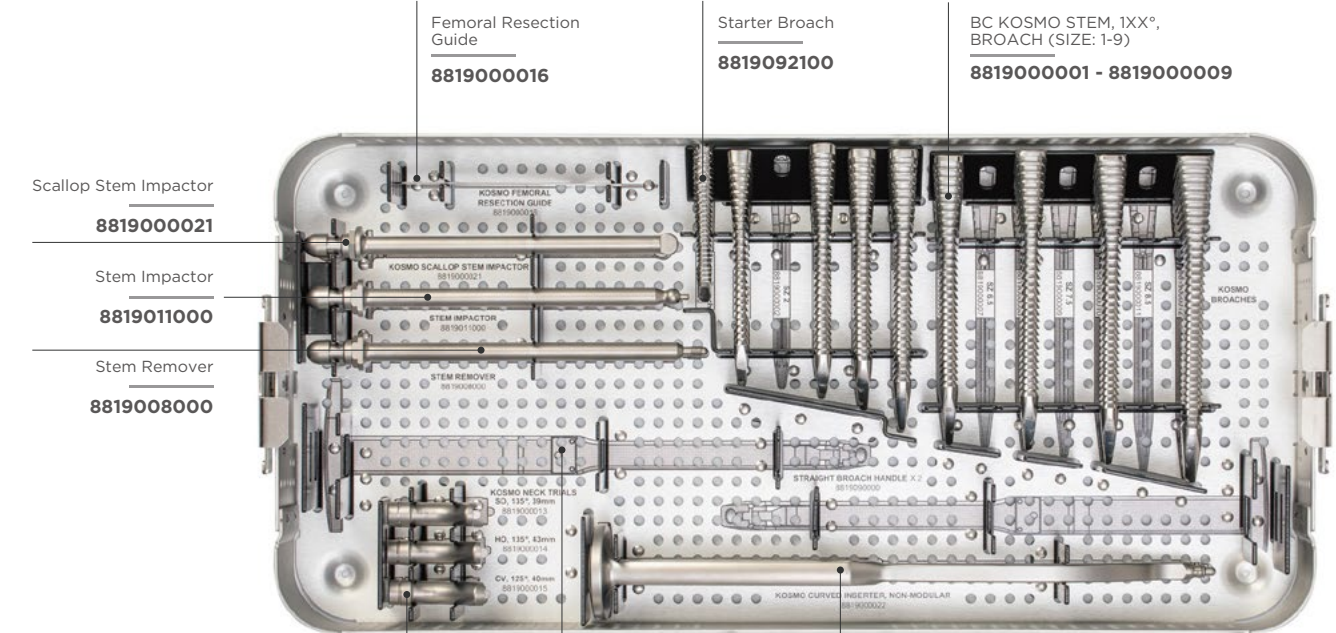

- Femoral Resection Guide **8819000016**
- Starter Broach **8819092100**
- BC KOSMO STEM, 1XX°, BROACH (SIZE: 1-9) **8819000001 - 8819000009**
- Scallop Stem Impactor **8819000021**
- Stem Impactor **8819011000**
- Stem Remover **8819008000**
- NECK TRIAL, 1XX° KOSMO, XXMM (ANGLE: 125°, 135° NECK LENGTHS: 39, 40, 43MM) **8819000013/14/15**
- BROACH HANDLE STRAIGHT **8819090000**
- CURVED INSERTER **8819000022**

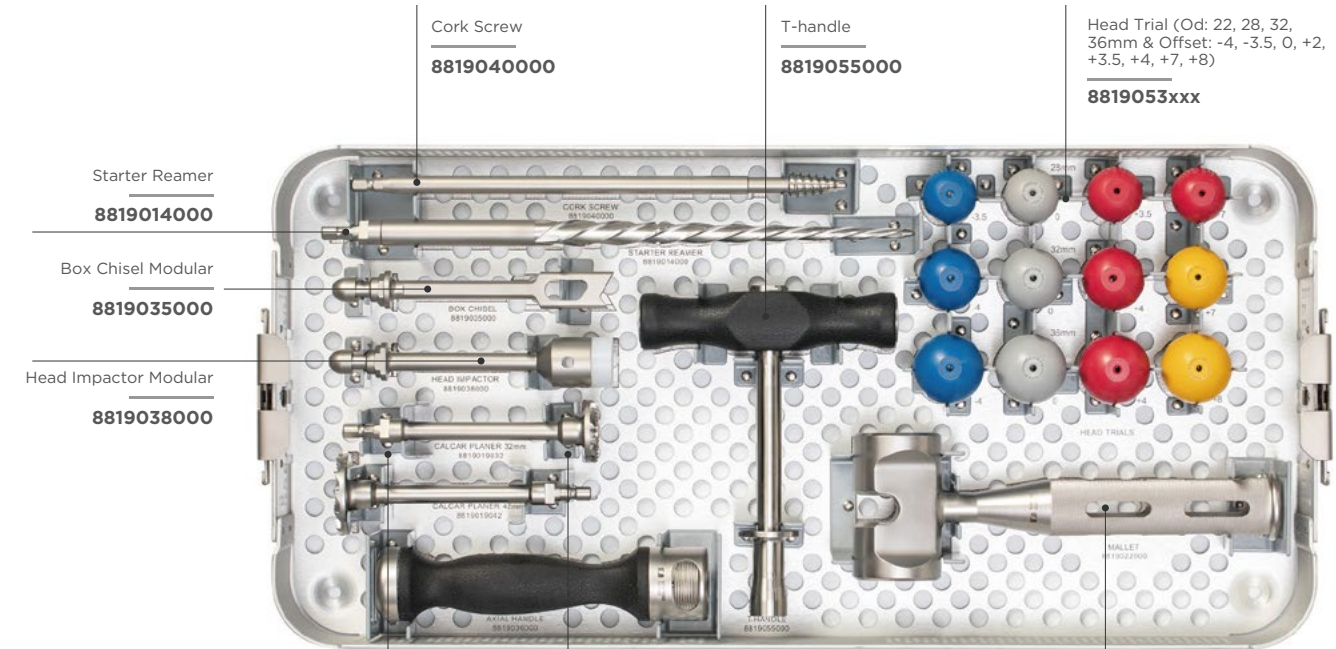

- Cork Screw **8819040000**
- T-handle **8819055000**
- Head Trial (Od: 22, 28, 32, 36mm & Offset: -4, -3.5, 0, +2, +3.5, +4, +7, +8) **8819053xxx**
- Starter Reamer **8819014000**
- Box Chisel Modular **8819035000**
- Head Impactor Modular **8819038000**
- Calcar Planer (Od: 32, 42mm) **88190190xx**
- Axial Handle Modular **8819036000**
- Mallet **8819022000**